

GEMS UNITED INDIAN SCHOOL- ABUDHABI

PRE BOARD EXAMINATION 2020-2021

SCIENCE (086)

GRADE: 10

Time: 3 hrs.

DATE: 7.12.2020

Max. Marks: 80

General Instructions:

- (i) The question paper comprises four sections A, B, C and D. There are 36 questions in the question paper. All questions are compulsory.
- (ii) Section–A - question no. 1 to 20 - all questions and parts thereof are of one mark each. These questions contain multiple choice questions (MCQs), very short answer questions and assertion - reason type questions. Answers to these should be given in one word or one sentence.
- (iii) Section–B - question no. 21 to 26 are short answer type questions, carrying 2 marks each. Answers to these questions should be in the range of 30 to 50 words.
- (iv) Section–C - question no. 27 to 33 are short answer type questions, carrying 3 marks each. Answers to these questions should be in the range of 50 to 80 words.
- (v) Section–D – question no. - 34 to 36 are long answer type questions carrying 5 marks each. Answer to these questions should be in the range of 80 to 120 words.
- (vi) There is no overall choice. However, internal choices have been provided in some questions. A student has to attempt only one of the alternatives in such questions.
- (vii) Wherever necessary, neat and properly labeled diagrams should be drawn.

Section A

- | | | |
|----|---|---|
| 1 | Ferrous sulphate decomposes with the evolution of a gas having a characteristic odour of burning sulphur. Write the chemical reaction involved and identify the type of reaction. | 1 |
| OR | | |
| | Give one example of a reaction which is a double displacement reaction as well as a precipitation reaction. | |
| 2 | What is the commercial name of calcium sulphate hemihydrate? | 1 |
| 3 | Which of the following is not observed in a homologous series? Give reason for your choice.
a) Change in chemical properties
b) Difference in $-CH_2$ and 14u molecular mass
c) Gradation in physical properties
d) Same functional group | 1 |

- 4 Why do the walls of the trachea not collapse when there is less air in it? 1
 Or
 Why do the rate of breathing in aquatic organisms much faster than in terrestrial organisms?
- 5 What happens to glucose that enters the nephron along with filtrate? 1
- 6 An aquarium requires regular cleaning whereas lakes normally do not. Give reason. 1
 Or
 How is ozone formed in the upper part of the atmosphere of the earth?
- 7 Why do inner walls of alimentary canal not digested although the digestive enzyme can digest all the materials that make the cells? 1
- 8 Why does the sky appear blue at noon? 1
- 9 Both a spherical mirror and a thin spherical lens have a focal length of (+)15 cm. What type of mirror and lens are these? 1
- 10 The image formed by a concave mirror is observed to be virtual, erect and larger than the object. Where is the object placed? 1

OR

- Name the part of a mirror through which a ray of light passes and gets reflected back along the same path.
- 11 Two coils of insulated copper wire are wound over a non-conducting cylinder as shown. Coil 1 has larger number of turns. 1
- i. Write your observation when,
- Key K is closed
 - Key K is opened.

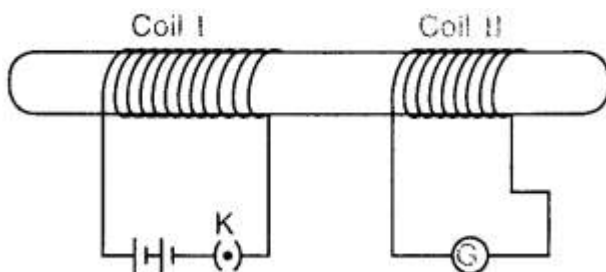

- (ii) Name and state the phenomenon responsible for the above observation.
- 12 A charged particle enters at right angle into a uniform magnetic field as shown. What should be the nature of charge on the particle if it begins to move in a direction pointing vertically out of the page due to its interaction with the magnetic field? 1

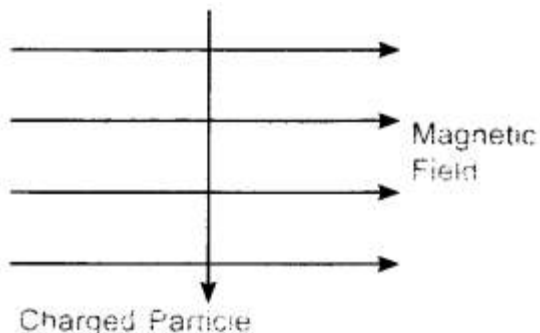

- 13 Two unequal resistances are connected in parallel. If you are not provided with any other parameters (eg. numerical values of R and I), what can be said about the voltage drop across the two resistors? 1

OR

How much energy is given to each coulomb of charge passing through a 6 V battery?

For question numbers 14, 15 and 16, two statements are given- one labeled Assertion (A) and the other labeled Reason (R). Select the correct answer to these questions from the codes (a), (b), (c) and (d) as given below:

- a) Both A and R are true, and R is correct explanation of the assertion.
 b) Both A and R are true, but R is not the correct explanation of the assertion.
 c) A is true, but R is false.
 d) A is false, but R is true.
- 14 **ASSERTION (A):** Calcium Carbonate on heating breaks into Calcium oxide and carbon dioxide gas. 1
REASON (R) : Calcium carbonate is a base.
- 15 **Assertion (A):** The Ozone layer in the atmosphere is getting depleted allowing more UV rays to reach earth. 1
Reason (R): CFC is broken down by UV radiation resulting attack on the Ozone molecules' damaging the Ozone umbrella of earth.
- 16 **Assertion (A):** When TT and tt pea plant were crossed, only tall plants were obtained in F1 progeny. 1
Reason (R): Tall allele was dominant over the short allele.

- 17 Read the following and answer any 4 questions from 17 (i) to 17 (v). 1X4

A solenoid is a long helical coil of wire through which a current is run in order to create a magnetic field. The magnetic field of the solenoid is the superposition of the fields due to the current through each coil. It is nearly uniform inside the solenoid and close to zero outside and is similar to the field of a bar magnet having a north pole at one end and a south pole at the other depending upon the direction of current flow. The magnetic field produced in the solenoid is dependent on a few factors such as, the current in the coil, number of turns per unit length etc.

The following graph is obtained by a researcher while doing an experiment to see the variation of the magnetic field with respect to the current in the solenoid.

The unit of magnetic field as given in the graph attached is in milli-Tesla (mT) and the current is given in Ampere.

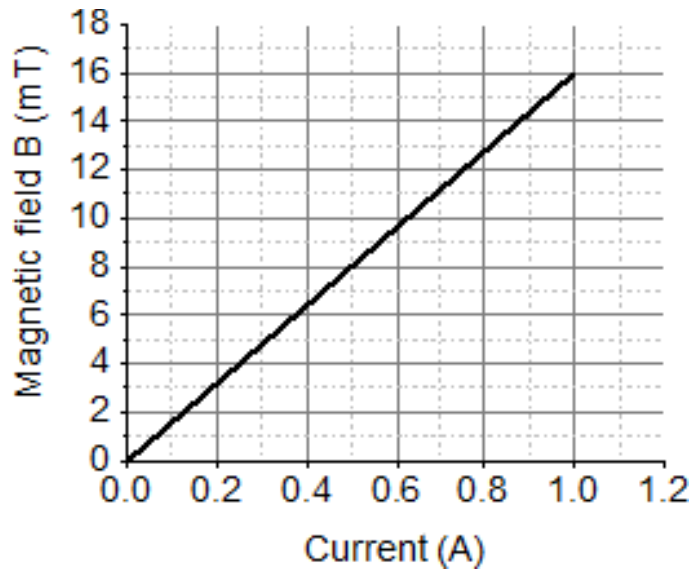

- (i) The strength of magnetic field inside a long current carrying straight solenoid is
- more at the ends than at the centre
 - minimum in the middle
 - same at all points
 - found to increase from one end to the other
- (ii) What will happen if a soft iron bar is placed inside the solenoid?
- The bar will be electrocuted resulting in short-circuit.
 - The bar will be magnetized as long as there is current in the circuit.
 - The bar will be magnetized permanently.
 - The bar will not be affected by any means.
- (iii) Magnetic lines of force inside current carrying solenoid are
- perpendicular to axis.
 - along the axis and are parallel to each other.
 - parallel inside the solenoid and circular at the ends.
 - circular.
- (iv) After analyzing the graph, a student writes the following statements.
- The magnetic field produced by the solenoid is inversely proportional to the current.
 - The magnetic field produced by the solenoid is directly proportional to the current.
 - The magnetic field produced by the solenoid is directly proportional to square of the current.
 - The magnetic field produced by the solenoid is independent of the current.
- Choose from the following which of the following would be the correct statement(s).
- Only IV
 - I and III and IV
 - I and II
 - Only II
- (v) From the graph, deduce which of the following statements is correct.
- For a current of 0.2A the magnetic field is 3 mT

- b. For larger currents, the magnetic field increases non-linearly.
- c. For a current of 0.2A the magnetic field is 0.3 mT
- d. There is not enough information to find the magnetic field corresponding to 0.2A current.

18

Read the following and answer any four questions from 18 (i) to 18 (v)

1X4

All living organisms such as plants and animals require energy from food. So food is essential for all living organisms. Plants are capable of making their own food by photosynthesis, but humans and animals cannot. Photosynthesis is the process used by plants, algae and certain bacteria to harness energy from sunlight and turn it into chemical energy.

- (i) Where do chlorophyll found in the plant cells?
 - a. Cytoplasm b. Chloroplast c. Mitochondria d. Vacuole
- (ii) The equation for photosynthesis is shown below.

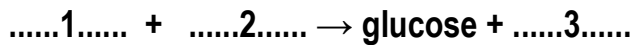

Which words correctly complete gaps 1, 2 and 3?

	1	2	3
A	carbon dioxide	light	oxygen
B	carbon dioxide	water	oxygen
C	oxygen	light	carbon dioxide
D	oxygen	water	carbon dioxide

- (iii) Study the experimental set up to study the photosynthesis. Both the set ups were kept in the dark room before six hours of the experiment and brought to bright sunlight, covered them with a glass bell jar. Watch the two set ups carefully and find the amount of Oxygen and CO₂ in both the set – ups after few hours in the sunlight. Choose the options in which both the set – ups match the most

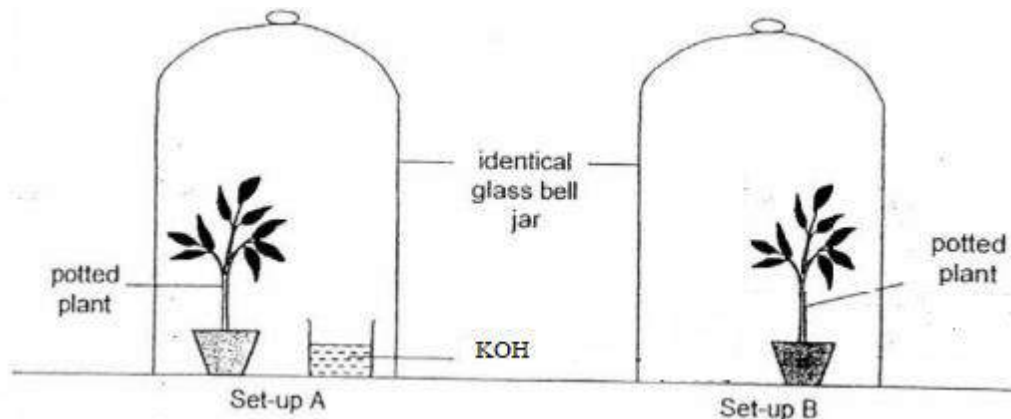

	Set- Up A	Set- Up B
A	Less O ₂	More O ₂
B	More CO ₂	Less O ₂
C	Less CO ₂	More CO ₂
D	More O ₂	Less CO ₂

- (iv) The graph shows the effect of temperature on the rate of photosynthesis. Which statement is consistent with the graph?

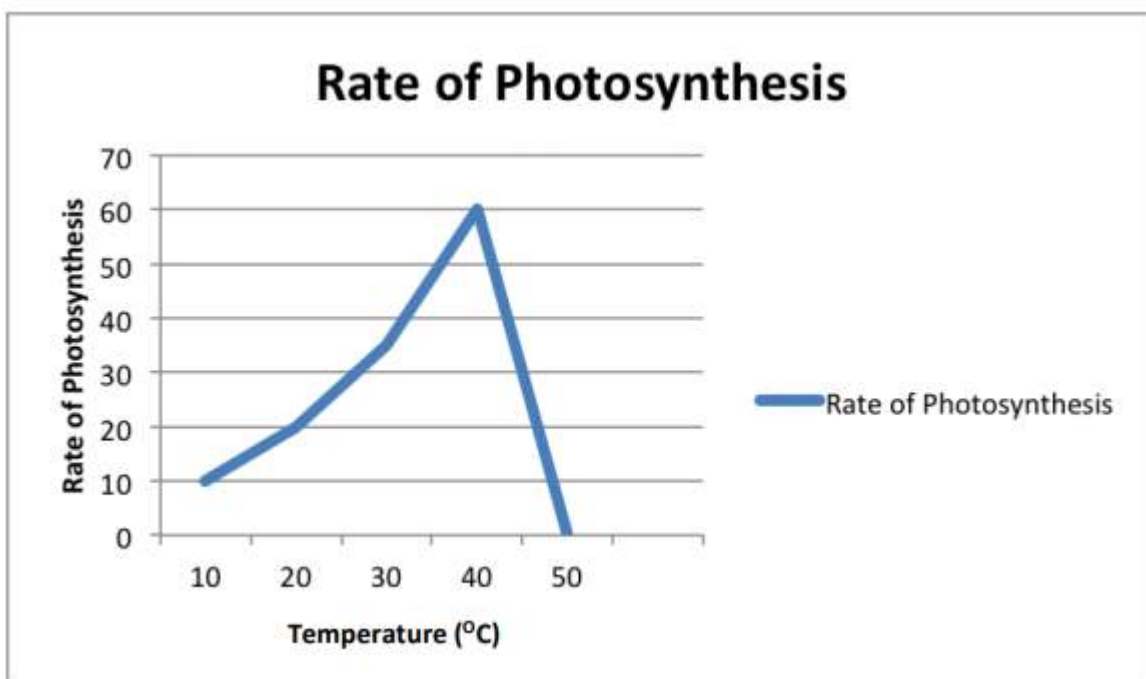

- A. Photosynthesis is a chemical reaction and the rate of chemical reactions increases with temperature.
- B. The rate of Photosynthesis above 40°C of temperatures slows down.
- C. At low temperatures, the rate of photosynthesis is limited
- D. No specific correlation between photosynthesis and temperature can be seen in the graph
- (v) Mark the incorrect statement about autotrophs
- Autotrophs synthesize carbohydrates from inorganic substances in the presence of sunlight and chlorophyll.
 - Autotrophs store carbohydrate in the form of starch
 - Autotrophs can convert carbon dioxide and water into carbohydrates even in the absence of light.
 - Autotrophs constitute the first trophic level in food chains.

19 Read the following and answer the questions from 19 (i) to 19 (iv). 1X 4
Modern periodic table arranges the elements in the increasing order of atomic number. It has 18 groups and 7 periods. Atomic numbers are consecutive in a period and increases in group in a pattern. Elements are divided into four blocks, s-block, p-block, d-block and f-block based on their electronic configuration. 78% of elements are metals, about 20 elements are non-metals and few elements like B, Si, Ge, As are metalloids. Metallic character increases down the group but decreases along the period from left to right. The physical and chemical properties vary periodically with their atomic numbers.

- (i) What happens to reactivity down the group 17?
- (ii) What type of compounds are formed by element belonging to group 14 and third period? Identify the element.
- (iii) What is formula of compound formed between Al and S?
- (iv) How does electronegativity varies along a period and why?

20 Read the following and answer any four questions from 20 (i) to 20 (v) 1X4

Rohit was standing outside his house in the afternoon enjoying the light drizzle after the heavy rain. Suddenly, he saw a rainbow in the sky. Immediately, he recalled his Physics class, where his teacher told him that dispersion is related to production of rainbow, which is a phenomenon of splitting white light into seven colours when passed through a glass prism. Sir Isaac Newton was the first to use a glass prism to obtain the spectrum of sunlight. He tried to split the colours of the spectrum of white light by using another similar prism. However, he could not get any more colours. But when he placed a second identical prism in an inverted position with the first prism, he found a beam of white light emerging from the other side of second prism. Finally, Rohit could reconnect the phenomena of rainbow with dispersion, i.e. splitting of white light into band of 7 colours or spectrum on passing through the glass prism.



Which colour of light has maximum deviation and which colour has minimum deviation?

- (i) a) Red, Orange
b) Blue, yellow

- c) Violet, Red
d) Blue, green
- (ii) Which phenomenon does not play role in the formation of rainbow?
- a) Dispersion
b) Interference
c) Refraction
d) Total internal reflection
- (iii) Arranging in the ascending order of wavelength, which one is true?
- a) Blue, Green, Red
b) Orange, Green, Red
c) Blue, Yellow, Green
d) Orange, Yellow, Green
- (iv) The dispersive power of prism depends upon
- (a) The shape of the prism
(b) The material of the prism
(c) The angle of the prism
(d) Height of the prism
- (v) Why will there be no dispersion, when two prisms are kept connected through their rectangular sides?
- a) It acts like a rectangular slab
b) Light falls normally
c) Both a and b
d) None of the above

SECTION B

- 21 Define homologous series of organic compounds. List its two characteristics. Write the name and formula of the first member of the series of alkenes. 2
- OR
- Give reasons for the following:
- (i)Element carbon forms compounds mainly by covalent bonding.
(ii)Diamond has a high melting point.
- 22 When the powder of a common metal is heated in an open china dish, its colour turns black. However, when hydrogen gas is passed over the hot black substance formed, it regains its original colour. Based on this information, answer the following questions : 2
- (i) What type of chemical reaction takes place in each of the two given steps ?
(ii)Name the metal initially taken in the powder form. Write balanced chemical equations for both these reactions.
- 23 The path of a ray of light passing through a glass prism is shown below : 2

••••

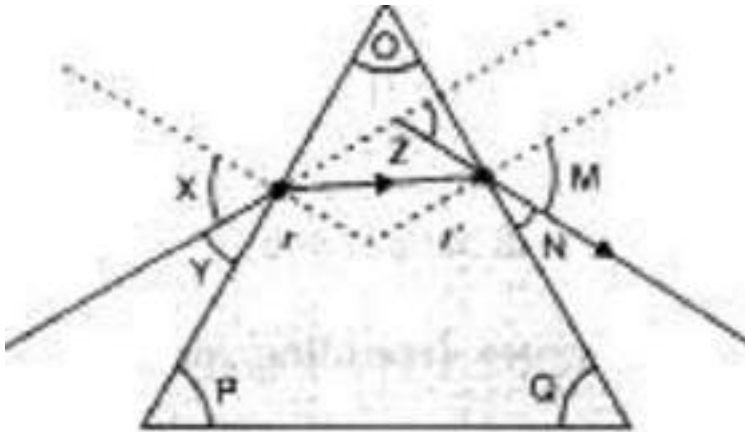

A In this diagram, the angle of prism, angle of incidence, angle of emergence and angle of deviation, respectively, have been represented by:

- a) O, Y, Z and N,
- b) O, X, M and Z,
- c) P, Y, M and Z,
- d) P, X, Z and N.

If the angle of incidence of light while leaving the denser medium is zero, the light would

- a) be reflected back
- b) go straight without any refraction
- c) be refracted
- d) end up at the boundary of the object

24

Given the circuit below...

2

- a. Calculate the equivalent resistance of the circuit.
- b. Calculate the current through the battery.

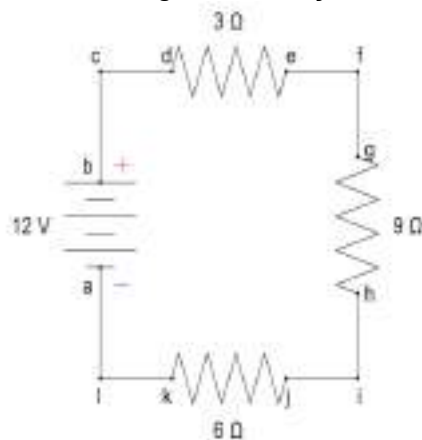

25

What are the ways in which glucose is oxidized to provide energy in man?

2

Or

During breathing cycle what is the advantage of residual volume of air in lungs? Explain.

26 What are the functions of lymph in our body? 2

SECTION C

27 The atomic numbers of elements A, B, C, D and E are given below : 3

Element	A	B	C	D	E
Atomic no.	7	10	12	4	19

From the above table, answer the following questions

- (a) Which two elements are chemically similar?
- (b) Which is an inert gas?
- (c) Which element belongs to 3rd period of periodic table?
- (d) Which element among these is a non-metal?

28 What happens when an aqueous solution of sodium sulphate reacts with an aqueous solution of barium chloride? State the physical conditions of reactants in which the reaction between them will not take place. Write the balanced chemical equation for the reaction and name the type of reaction. 3

29 (a) Arrange the following metals in decreasing order of their reactivity Cu, Ca, Mg, Na, Zn. (b) You are provided with three metals: sodium, magnesium and copper Using only water as the reactant how will you identify each of them? (c) Which metal listed in (a) is most likely to occur in the native state. 3

30 i. A ray of light, incident obliquely on a face of a rectangular glass slab placed in air emerges from the opposite face parallel to the incident ray. State two factors on which the lateral displacement of the emergent ray depends. 3

- i. A ray of light enters a rectangular glass slab of refractive index 1.5. It is found that the ray emerges from the opposite face of the slab without being displaced. If its speed in air is 3×10^8 ms⁻¹ then what is its speed in glass?

31 Illustrate with the help of a schematic representation of transport and exchange of oxygen and carbon dioxide in human body 3

32 Study the following cross and answer the questions that below : 3

F1 Generation All Green and Round seeds

F2 Generation :

Green and Round (9)	Green & wrinkled (3)
Yellow and Round (3)	Yellow and Wrinkled(1)

(a) Write down the phenotype of parent generation, which can give rise to the given F1 and F2 generations?

(b) List the dominant and recessive characters.

(c) Are the characters linked or independent? What genetic mechanism account for these results?

33 Mention any two characteristics of a food chain. 3

What will be the amount of energy available to the organisms of the 3rd trophic level of a food chain, If the energy available at the first trophic level is 20,000 joules

SECTION D

34 I) a) Explain the action of dilute hydrochloric acid on the following with chemical equation: 5

(i) Magnesium ribbon (ii) Sodium hydroxide (iii) Crushed egg shells

b) A metal compound 'X' reacts with dil. H_2SO_4 to produce effervescence, The gas evolved extinguishes a burning candle. If one of the compound formed is calcium sulphate, then what is 'X' and the gas evolved? Also, write a balanced chemical equation for the reaction which occurred.

OR

II) A compound which is prepared from gypsum has the property of hardening when mixed with proper quantity of water.

(i) Identify the compound.

(ii) Write the chemical equation for its preparation.

Name the products formed in each case when

(a) Hydrochloric acid reacts with caustic soda.

(b) Granulated zinc reacts with caustic soda.

(c) Carbon dioxide is passed into lime water.

35 i. a) Find the current flowing through the following electric circuit. 5

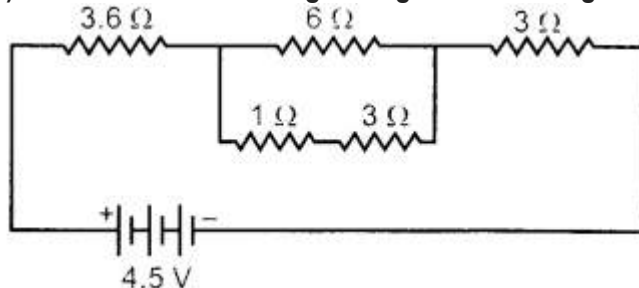

b) When a high resistance voltmeter is connected directly across a resistor, its reading is 2 V. An electric cell is sending the current of 0.4 A, (measured by an ammeter) in the electric circuit in which a rheostat is also connected to vary the current.

(a) Draw an equivalent labelled circuit for the given data.

(b) Find the resistance of the resistor.

(c) Name and state the law applicable in the given case. A graph is drawn between a set of values of potential difference (V) across the resistor and current (I) flowing through it. Show the nature of graph thus obtained.

OR

i. For the current carrying solenoid as shown below, draw magnetic field lines.

Give reason and explain that out of the three points A, B and C at which point the field strength is maximum and at which point it is minimum.

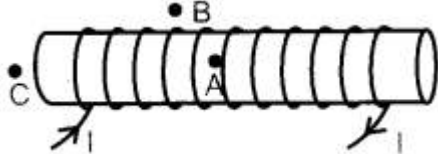

ii. a. Define a magnetic field line.

b. Imagine that you are sitting in a chamber with your back to one wall. An electron beam, moving horizontally from back wall towards the front wall, is deflected by a strong magnetic field to your right side. What is the direction of magnetic field?

c. Name and state the rule used to find the direction of magnetic field.

a. Identify and name the modes of asexual reproduction in each of the following organism:

(i) Hydra

(ii) Planaria

(iii) Amoeba

(iv) Spirogyra

(v) Rhizopus

b. Why can fertilization not take place in flowers, if pollination does not occur?

c. List any two contraceptive methods. State any two reasons for adopting the contraceptive methods.