

AREA RELATED TO CIRCLES

(A) Main Concepts and Results

Perimeters and areas of simple closed figures. Circumference and area of a circle. Area of a circular path (i.e., ring). Sector of a circle and its central angle – Major and Minor sectors. Segment of a circle – Major and Minor segments.

- Circumference of a circle = $2 \pi r$ and area of a circle = πr^2 , where r is the radius of the circle.
- Area of the circular path formed by two concentric circles of radii r_1 and r_2 ($r_1 > r_2$) = $\pi r_1^2 - \pi r_2^2 = \pi(r_1^2 - r_2^2)$.
- Area of the sector of a circle of radius r with central angle $\theta = \frac{\theta}{360} \times \pi r^2$, where θ is measured in degrees.
- Length of the arc of the sector of a circle of radius r with central angle $\theta = \frac{\theta}{360} \times 2 \pi r$, where θ is measured in degrees.
- Area of the minor segment APB of the circle in Fig. 11.1 = area of sector OAPB – area of Δ OAB.
- Area of the major sector of a circle of radius r = πr^2 – area of the corresponding minor sector.

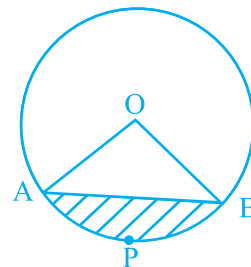

Fig. 11.1

- Area of the major segment of a circle of radius $r = \pi r^2 -$ area of the corresponding minor segment.

Note: Unless stated otherwise, the value of π is to be taken as $\frac{22}{7}$.

(B) Multiple Choice Questions

Choose the correct answer from the given four options:

Sample Question 1 : If the area of a circle is 154 cm^2 , then its perimeter is

- (A) 11 cm (B) 22 cm (C) 44 cm (D) 55 cm

Solution : Answer (C)

Sample Question 2 : If θ is the angle (in degrees) of a sector of a circle of radius r , then area of the sector is

- (A) $\frac{\pi r^2 \theta}{360}$ (B) $\frac{\pi r^2 \theta}{180}$ (C) $\frac{2 \pi r \theta}{360}$ (D) $\frac{2 \pi r \theta}{180}$

Solution : Answer (A)

EXERCISE 11.1

Choose the correct answer from the given four options:

- If the sum of the areas of two circles with radii R_1 and R_2 is equal to the area of a circle of radius R , then

(A) $R_1 + R_2 = R$ (B) $R_1^2 + R_2^2 = R^2$
 (C) $R_1 + R_2 < R$ (D) $R_1^2 + R_2^2 < R^2$
- If the sum of the circumferences of two circles with radii R_1 and R_2 is equal to the circumference of a circle of radius R , then

(A) $R_1 + R_2 = R$ (B) $R_1 + R_2 > R$
 (C) $R_1 + R_2 < R$ (D) Nothing definite can be said about the relation among R_1 , R_2 and R .

3. If the circumference of a circle and the perimeter of a square are equal, then
- (A) Area of the circle = Area of the square
 - (B) Area of the circle > Area of the square
 - (C) Area of the circle < Area of the square
 - (D) Nothing definite can be said about the relation between the areas of the circle and square.
4. Area of the largest triangle that can be inscribed in a semi-circle of radius r units is
- (A) r^2 sq. units
 - (B) $\frac{1}{2} r^2$ sq. units
 - (C) $2 r^2$ sq. units
 - (D) $\sqrt{2} r^2$ sq. units
5. If the perimeter of a circle is equal to that of a square, then the ratio of their areas is
- (A) 22 : 7
 - (B) 14 : 11
 - (C) 7 : 22
 - (D) 11 : 14
6. It is proposed to build a single circular park equal in area to the sum of areas of two circular parks of diameters 16 m and 12 m in a locality. The radius of the new park would be
- (A) 10 m
 - (B) 15 m
 - (C) 20 m
 - (D) 24 m
7. The area of the circle that can be inscribed in a square of side 6 cm is
- (A) $36 \pi \text{ cm}^2$
 - (B) $18 \pi \text{ cm}^2$
 - (C) $12 \pi \text{ cm}^2$
 - (D) $9 \pi \text{ cm}^2$
8. The area of the square that can be inscribed in a circle of radius 8 cm is
- (A) 256 cm^2
 - (B) 128 cm^2
 - (C) $64\sqrt{2} \text{ cm}^2$
 - (D) 64 cm^2
9. The radius of a circle whose circumference is equal to the sum of the circumferences of the two circles of diameters 36cm and 20 cm is
- (A) 56 cm
 - (B) 42 cm
 - (C) 28 cm
 - (D) 16 cm
10. The diameter of a circle whose area is equal to the sum of the areas of the two circles of radii 24 cm and 7 cm is
- (A) 31 cm
 - (B) 25 cm
 - (C) 62 cm
 - (D) 50 cm

(C) Short Answer Questions with Reasoning

Sample Question 1 : Is the following statement true? Give reasons for your answer.

Area of a segment of a circle = area of the corresponding sector – area of the corresponding triangle.

Solution : Statement is not true. It is true only for a minor segment. In the case of a major segment, area of the triangle will have to be added to the corresponding area of the sector.

Sample Question 2 : In Fig. 11.2, a circle is inscribed in a square of side 5 cm and another circle is circumscribing the square. Is it true to say that area of the outer circle is two times the area of the inner circle? Give reasons for your answer.

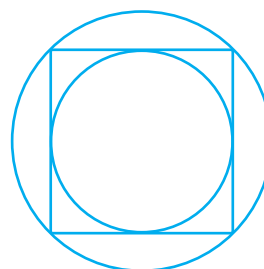

Fig.11.2

Solution : It is true, because diameter of the inner circle = 5 cm and that of outer circle = diagonal of the square = $5\sqrt{2}$ cm.

$$\text{So, } A_1 = \pi \left(\frac{5\sqrt{2}}{2} \right)^2 \text{ and } A_2 = \pi \left(\frac{5}{2} \right)^2, \text{ giving } \frac{A_1}{A_2} = 2$$

EXERCISE 11.2

1. Is the area of the circle inscribed in a square of side a cm, $\pi a^2 \text{ cm}^2$? Give reasons for your answer.
2. Will it be true to say that the perimeter of a square circumscribing a circle of radius a cm is $8a$ cm? Give reasons for your answer.
3. In Fig 11.3, a square is inscribed in a circle of diameter d and another square is circumscribing the circle. Is the area of the outer square four times the area of the inner square? Give reasons for your answer.

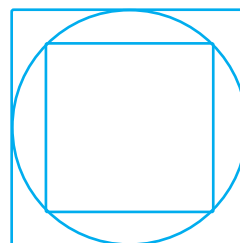

Fig.11.3

4. Is it true to say that area of a segment of a circle is less than the area of its corresponding sector? Why?
5. Is it true that the distance travelled by a circular wheel of diameter d cm in one revolution is $2\pi d$ cm? Why?
6. In covering a distance s metres, a circular wheel of radius r metres makes $\frac{s}{2\pi r}$ revolutions. Is this statement true? Why?
7. The numerical value of the area of a circle is greater than the numerical value of its circumference. Is this statement true? Why?
8. If the length of an arc of a circle of radius r is equal to that of an arc of a circle of radius $2r$, then the angle of the corresponding sector of the first circle is double the angle of the corresponding sector of the other circle. Is this statement false? Why?
9. The areas of two sectors of two different circles with equal corresponding arc lengths are equal. Is this statement true? Why?
10. The areas of two sectors of two different circles are equal. Is it necessary that their corresponding arc lengths are equal? Why?
11. Is the area of the largest circle that can be drawn inside a rectangle of length a cm and breadth b cm ($a > b$) is πb^2 cm²? Why?
12. Circumferences of two circles are equal. Is it necessary that their areas be equal? Why?
13. Areas of two circles are equal. Is it necessary that their circumferences are equal? Why?
14. Is it true to say that area of a square inscribed in a circle of diameter p cm is p^2 cm²? Why?

(D) Short Answer Questions

Sample Question 1: Find the diameter of the circle whose area is equal to the sum of the areas of the two circles of diameters 20 cm and 48 cm.

Solution : Here, radius r_1 of first circle = $\frac{20}{2}$ cm = 10 cm and radius r_2 of the second circle = $\frac{48}{2}$ cm = 24 cm

Therefore, sum of their areas = $\pi r_1^2 + \pi r_2^2 = \pi (10)^2 + \pi (24)^2 = \pi \times 676$ (1)

Let the radius of the new circle be r cm. Its area = πr^2 (2)

Therefore, from (1) and (2),

$$\pi r^2 = \pi \times 676$$

or $r^2 = 676$

i.e., $r = 26$

Thus, radius of the new circle = 26 cm

Hence, diameter of the new circle = 2×26 cm = 52 cm

Sample Question 2 : Find the area of a sector of circle of radius 21 cm and central angle 120° .

Solution : Area of the sector = $\frac{\theta}{360} \times \pi r^2$

$$= \frac{120}{360} \times \frac{22}{7} \times (21)^2 \text{ cm}^2$$

$$= 22 \times 21 \text{ cm}^2$$

$$= 462 \text{ cm}^2$$

Sample Question 3 : In Fig 11.4, a circle of radius 7.5 cm is inscribed in a square. Find the area of the shaded region (Use $\pi = 3.14$)

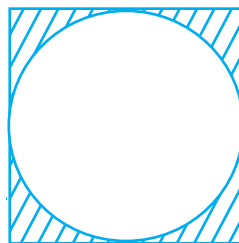

Fig.11.4

Solution : Area of the circle = πr^2

$$= 3.14 \times (7.5)^2 \text{ cm}^2$$

$$= 176.625 \text{ cm}^2$$

Clearly, side of the square = diameter of the circle = 15 cm

So, area of the square = $15^2 \text{ cm}^2 = 225 \text{ cm}^2$

Therefore, area of the shaded region

$$= 225 \text{ cm}^2 - 176.625 \text{ cm}^2 = 48.375 \text{ cm}^2$$

Sample Question 4 : Area of a sector of a circle of radius 36 cm is $54\pi \text{ cm}^2$. Find the length of the corresponding arc of the sector.

Solution : Let the central angle (in degrees) be θ .

So,
$$\frac{\pi \times (36)^2 \theta}{360} = 54\pi$$

or
$$\theta = \frac{54 \times 360}{36 \times 36} = 15$$

Now, length of the arc =
$$\frac{\theta}{360} \times 2\pi r$$

$$= \frac{15}{360} \times 2\pi \times 36 \text{ cm}$$

$$= 3\pi \text{ cm}$$

EXERCISE 11.3

- Find the radius of a circle whose circumference is equal to the sum of the circumferences of two circles of radii 15 cm and 18 cm.
- In Fig. 11.5, a square of diagonal 8 cm is inscribed in a circle. Find the area of the shaded region.

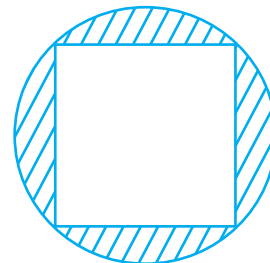

Fig.11.5

3. Find the area of a sector of a circle of radius 28 cm and central angle 45° .
4. The wheel of a motor cycle is of radius 35 cm. How many revolutions per minute must the wheel make so as to keep a speed of 66 km/h?
5. A cow is tied with a rope of length 14 m at the corner of a rectangular field of dimensions $20\text{m} \times 16\text{m}$. Find the area of the field in which the cow can graze.
6. Find the area of the flower bed (with semi-circular ends) shown in Fig. 11.6.

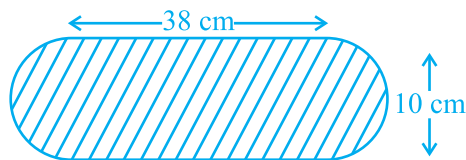

Fig. 11.6

7. In Fig. 11.7, AB is a diameter of the circle, AC = 6 cm and BC = 8 cm. Find the area of the shaded region (Use $\pi = 3.14$).

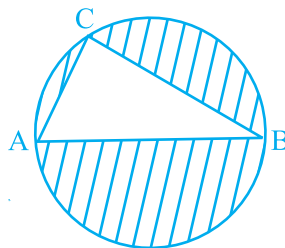

Fig. 11.7

8. Find the area of the shaded field shown in Fig. 11.8.

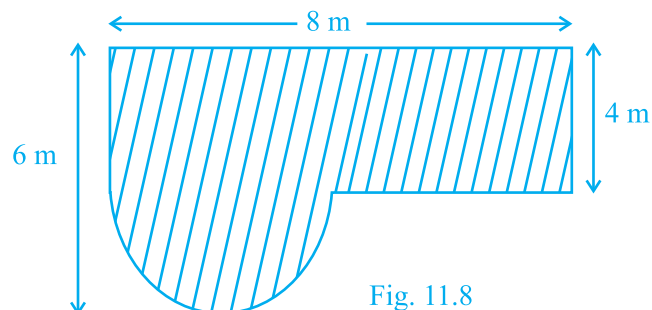

Fig. 11.8

9. Find the area of the shaded region in Fig. 11.9.

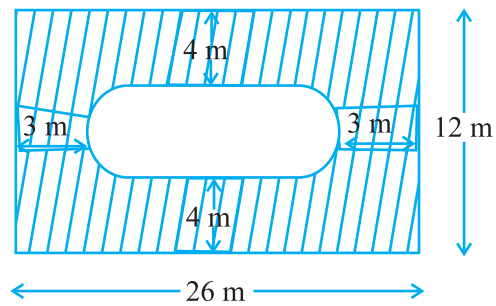

Fig. 11.9

10. Find the area of the minor segment of a circle of radius 14 cm, when the angle of the corresponding sector is 60° .
11. Find the area of the shaded region in Fig. 11.10, where arcs drawn with centres A, B, C and D intersect in pairs at mid-points P, Q, R and S of the sides AB, BC, CD and DA, respectively of a square ABCD (Use $\pi = 3.14$).

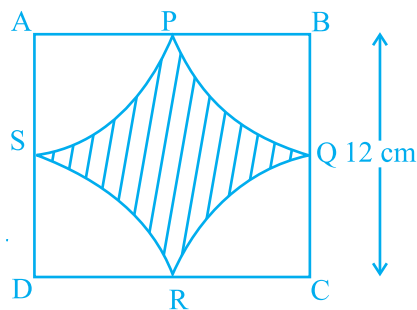

Fig. 11.10

12. In Fig. 11.11, arcs are drawn by taking vertices A, B and C of an equilateral triangle of side 10 cm. to intersect the sides BC, CA and AB at their respective mid-points D, E and F. Find the area of the shaded region (Use $\pi = 3.14$).

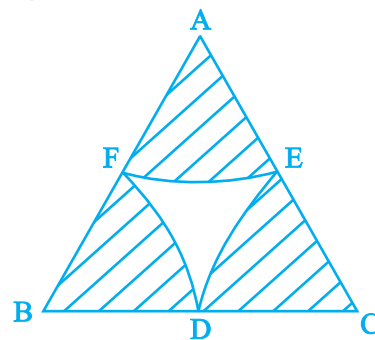

Fig. 11.11

13. In Fig. 11.12, arcs have been drawn with radii 14 cm each and with centres P, Q and R. Find the area of the shaded region.

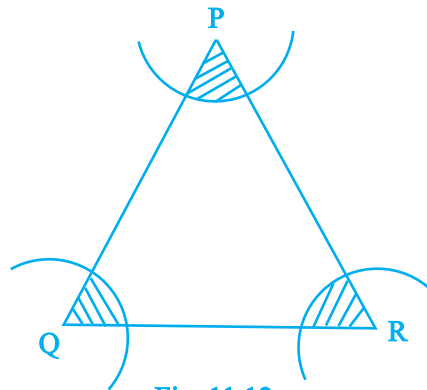

Fig. 11.12

14. A circular park is surrounded by a road 21 m wide. If the radius of the park is 105 m, find the area of the road.
15. In Fig. 11.13, arcs have been drawn of radius 21 cm each with vertices A, B, C and D of quadrilateral ABCD as centres. Find the area of the shaded region.

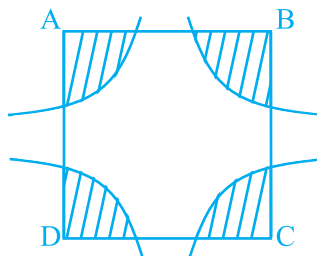

Fig. 11.13

16. A piece of wire 20 cm long is bent into the form of an arc of a circle subtending an angle of 60° at its centre. Find the radius of the circle.

(E) Long Answer Questions

Sample Question 1 : A chord of a circle of radius 20 cm subtends an angle of 90° at the centre. Find the area of the corresponding major segment of the circle. (Use $\pi = 3.14$).

Solution : Let AB be the chord of a circle of radius 10 cm, with O as the centre of the circle (see Fig. 11.14).

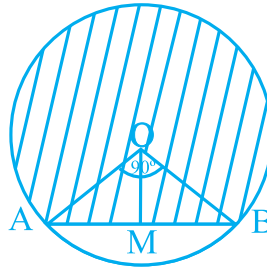

Fig. 11.14

Here, $\angle A O B = 90^\circ$ and we have to find the area of the major segment (which is shaded). As $\angle A O B = 90^\circ$, therefore angle of the major sector = $360^\circ - 90^\circ = 270^\circ$

$$\begin{aligned} \text{So, area of the major sector} &= \frac{270}{360} \times \pi \times (10)^2 \text{ cm}^2 \\ &= \frac{3}{4} \times 3.14 \times 100 \text{ cm}^2 \\ &= 75 \times 3.14 \text{ cm}^2 = 235.5 \text{ cm}^2 \end{aligned}$$

Now, to find the area of ΔOAB , draw $OM \perp AB$.

$$\text{So, } AM = \frac{1}{2} AB \text{ and } \angle AOM = \frac{1}{2} \times 90^\circ = 45^\circ.$$

$$\text{Now, } \frac{AM}{OA} = \sin 45^\circ = \frac{1}{\sqrt{2}}$$

$$\text{So, } AM = 10 \times \frac{1}{\sqrt{2}} \text{ cm.}$$

$$\text{Therefore, } AB = 10\sqrt{2} \text{ cm and } OM = OA \cos 45^\circ = 10 \times \frac{1}{\sqrt{2}} \text{ cm} = 5\sqrt{2} \text{ cm}$$

$$\text{So, area of } \Delta OAB = \frac{1}{2} \text{ base} \times \text{height}$$

$$= \frac{1}{2} 10\sqrt{2} \times 5\sqrt{2} \text{ cm}^2 = 50 \text{ cm}^2$$

Therefore, the area of the required major segment
 $= 235.5 \text{ cm}^2 + 50 \text{ cm}^2 = 285.5 \text{ cm}^2$

Another method for the area of ΔOAB

As, $\angle AOB = 90^\circ$,

Therefore, area of $\Delta OAB = \frac{1}{2} OA \times OB$

$$= \frac{1}{2} 10 \times 10 \text{ cm}^2 = 50 \text{ cm}^2$$

Sample Question 2 : With the vertices A, B and C of a triangle ABC as centres, arcs are drawn with radii 5 cm each as shown in Fig. 11.15. If $AB = 14$ cm, $BC = 48$ cm and $CA = 50$ cm, then find the area of the shaded region. (Use $\pi = 3.14$).

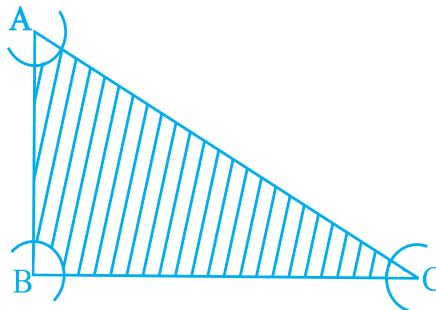

Fig. 11.15

Solution : Area of the sector with angle A

$$= \frac{\angle A}{360^\circ} \times \pi r^2 = \frac{\angle A}{360^\circ} \times \pi \times (5)^2 \text{ cm}^2$$

Area of the sector with angle B

$$= \frac{\angle B}{360^\circ} \times \pi r^2 = \frac{\angle B}{360^\circ} \times \pi \times (5)^2 \text{ cm}^2$$

and the area of the sector with angle C = $\frac{\angle C}{360^\circ} \times \pi \times (5)^2 \text{ cm}^2$

Therefore, sum of the areas (in cm^2) of the three sectors

$$\begin{aligned} &= \frac{\angle A}{360^\circ} \times \pi \times (5)^2 + \frac{\angle B}{360^\circ} \times \pi \times (5)^2 + \frac{\angle C}{360^\circ} \times \pi \times (5)^2 \\ &= \frac{\angle A + \angle B + \angle C}{360^\circ} \times 25 \pi \\ &= \frac{180^\circ}{360^\circ} \times 25 \pi \text{ cm}^2 \quad (\text{Because } \angle A + \angle B + \angle C = 180^\circ) \\ &= 25 \times \frac{\pi}{2} \text{ cm}^2 = 25 \times 1.57 \text{ cm}^2 = 39.25 \text{ cm}^2 \end{aligned}$$

Now, to find area of ΔABC , we find

$$s = \frac{a + b + c}{2} = \frac{48 + 50 + 14}{2} \text{ cm} = 56 \text{ cm}$$

By Heron's Formula,

$$\begin{aligned} \text{ar (ABC)} &= \sqrt{s(s-a)(s-b)(s-c)} \\ &= \sqrt{56 \times 8 \times 6 \times 42} \text{ cm}^2 \\ &= 336 \text{ cm}^2 \end{aligned}$$

So, area of the shaded region = area of the ΔABC – area of the three sectors
 $= (336 - 39.25) \text{ cm}^2 = 296.75 \text{ cm}^2$

Alternate Method for ar (ABC)

Here, $AB^2 + BC^2 = (14)^2 + (48)^2 = 2500 = (50)^2 = (CA)^2$

So, $\angle B = 90^\circ$ (By converse of Pythagoras Theorem)

Therefore, $\text{ar (ABC)} = \frac{1}{2} AB \times BC = \frac{1}{2} \times 14 \times 48 \text{ cm}^2 = 336 \text{ cm}^2$

Sample Question 3 : A calf is tied with a rope of length 6 m at the corner of a square grassy lawn of side 20 m. If the length of the rope is increased by 5.5m, find the increase in area of the grassy lawn in which the calf can graze.

Solution : Let the calf be tied at the corner A of the square lawn (see Fig. 11.16)

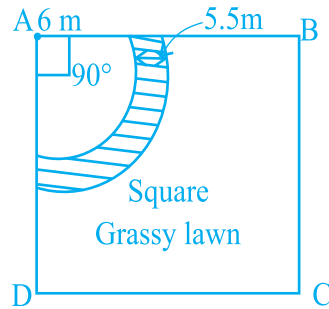

Fig. 11.16

Then, the increase in area = Difference of the two sectors of central angle 90° each and radii 11.5 m (6 m + 5.5 m) and 6 m, which is the shaded region in the figure.

So, required increase in area

$$\begin{aligned}
 &= \left[\frac{90}{360} \times \pi \times 11.5^2 - \frac{90}{360} \pi \times 6^2 \right] \text{m}^2 \\
 &= \frac{\pi}{4} \times (11.5 + 6) (11.5 - 6) \text{m}^2 \\
 &= \frac{22}{7 \times 4} \times 17.5 \times 5.5 \text{m}^2 \\
 &= 75.625 \text{m}^2 .
 \end{aligned}$$

EXERCISE 11.4

1. The area of a circular playground is 22176 m^2 . Find the cost of fencing this ground at the rate of Rs 50 per metre.
2. The diameters of front and rear wheels of a tractor are 80 cm and 2 m respectively. Find the number of revolutions that rear wheel will make in covering a distance in which the front wheel makes 1400 revolutions.
3. Sides of a triangular field are 15 m, 16 m and 17 m. With the three corners of the field a cow, a buffalo and a horse are tied separately with ropes of length 7 m each to graze in the field. Find the area of the field which cannot be grazed by the three animals.

4. Find the area of the segment of a circle of radius 12 cm whose corresponding sector has a central angle of 60° (Use $\pi = 3.14$).
5. A circular pond is 17.5 m in diameter. It is surrounded by a 2 m wide path. Find the cost of constructing the path at the rate of Rs 25 per m^2 .
6. In Fig. 11.17, ABCD is a trapezium with $AB \parallel DC$, $AB = 18$ cm, $DC = 32$ cm and distance between AB and DC = 14 cm. If arcs of equal radii 7 cm with centres A, B, C and D have been drawn, then find the area of the shaded region of the figure.

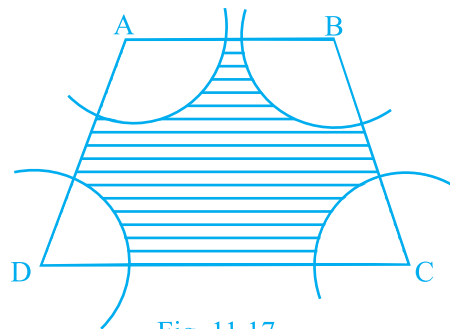

Fig. 11.17

7. Three circles each of radius 3.5 cm are drawn in such a way that each of them touches the other two. Find the area enclosed between these circles.
8. Find the area of the sector of a circle of radius 5 cm, if the corresponding arc length is 3.5 cm.
9. Four circular cardboard pieces of radii 7 cm are placed on a paper in such a way that each piece touches other two pieces. Find the area of the portion enclosed between these pieces.
10. On a square cardboard sheet of area 784 cm^2 , four congruent circular plates of maximum size are placed such that each circular plate touches the other two plates and each side of the square sheet is tangent to two circular plates. Find the area of the square sheet not covered by the circular plates.
11. Floor of a room is of dimensions $5 \text{ m} \times 4 \text{ m}$ and it is covered with circular tiles of diameters 50 cm each as shown in Fig. 11.18. Find the area of floor

that remains uncovered with tiles. (Use $\pi = 3.14$)

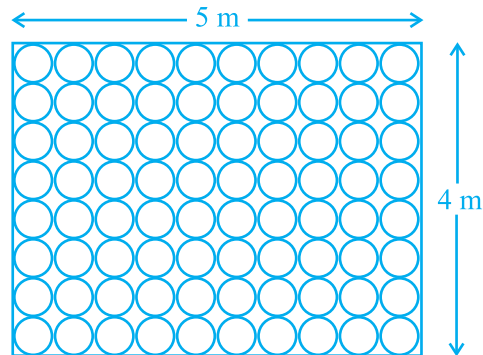

Fig. 11.18

12. All the vertices of a rhombus lie on a circle. Find the area of the rhombus, if area of the circle is 1256 cm^2 . (Use $\pi = 3.14$).
13. An archery target has three regions formed by three concentric circles as shown in Fig. 11.19. If the diameters of the concentric circles are in the ratio 1: 2:3, then find the ratio of the areas of three regions.

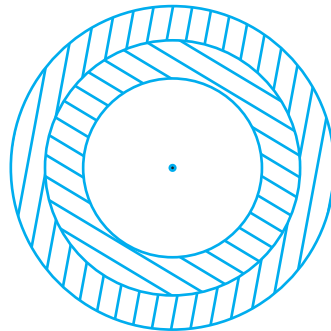

Fig. 11.19

14. The length of the minute hand of a clock is 5 cm. Find the area swept by the minute hand during the time period 6 : 05 a m and 6 : 40 a m.
15. Area of a sector of central angle 200° of a circle is 770 cm^2 . Find the length of the corresponding arc of this sector.

16. The central angles of two sectors of circles of radii 7 cm and 21 cm are respectively 120° and 40° . Find the areas of the two sectors as well as the lengths of the corresponding arcs. What do you observe?
17. Find the area of the shaded region given in Fig. 11.20.

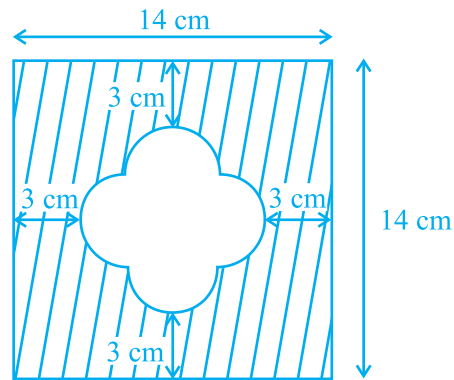

Fig. 11.20

18. Find the number of revolutions made by a circular wheel of area 1.54 m^2 in rolling a distance of 176 m.
19. Find the difference of the areas of two segments of a circle formed by a chord of length 5 cm subtending an angle of 90° at the centre.
20. Find the difference of the areas of a sector of angle 120° and its corresponding major sector of a circle of radius 21 cm.