

CHAPTER

**13**

**Surface Areas and Volumes**

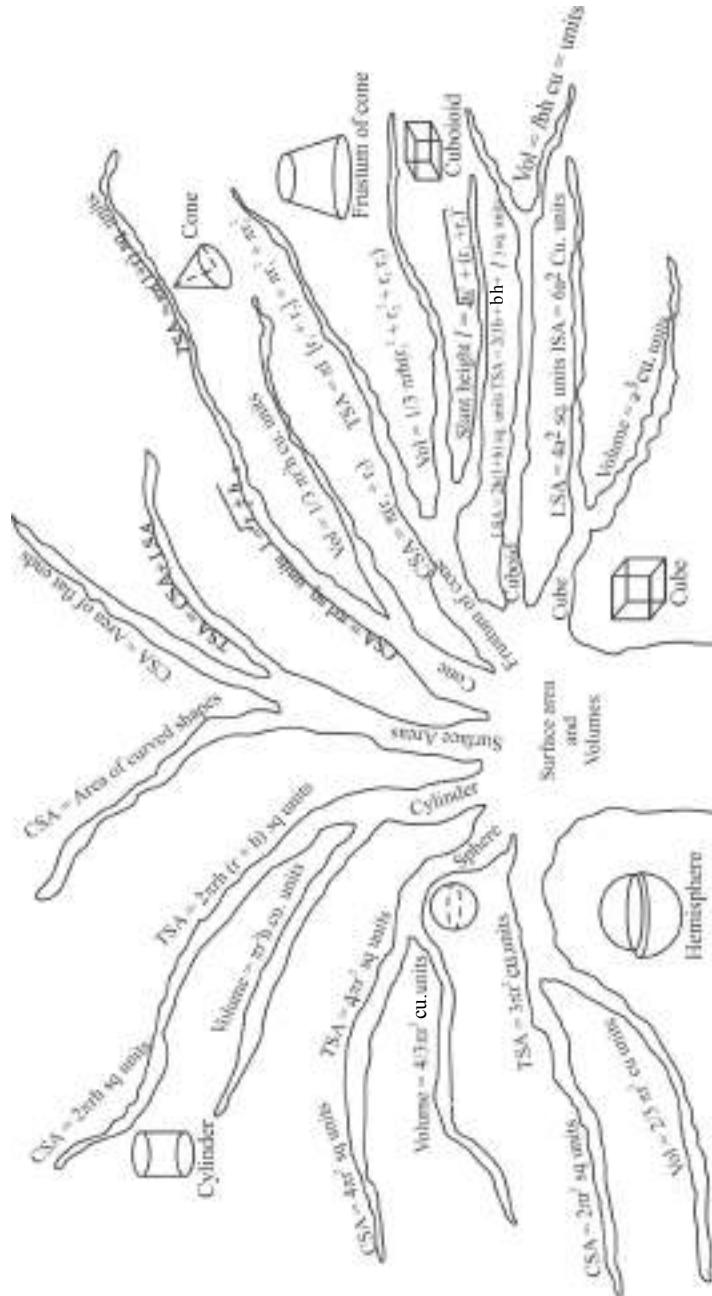

## KEY POINTS

1. **Cuboid:** 3-D shapes like a book, a match box, an almirah, a room etc. are called Cuboid.

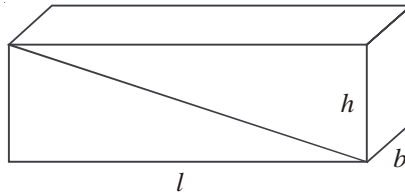

For cuboid length =  $l$ , breadth =  $b$ , height =  $h$

$$\text{Volume} = l \times b \times h$$

$$\text{Lateral surface area of solid cuboid} = 2h(l + b)$$

$$\text{Total surface area of solid cuboid} = 2(lb + bh + hl)$$

2. **Cube:** 3-D shapes like ice-cubes, dice, etc. are called cube.

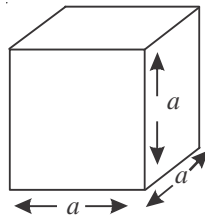

In cube, length = breadth = height =  $a$

$$\text{Volume} = a^3$$

$$\text{Lateral surface area of solid cube} = 4a^2$$

$$\text{Total surface area of solid cube} = 6a^2$$

3. **Cylinder:** 3-D shapes like jars, circular pillars, circular pipes, rood rollers etc. are called cylinder.

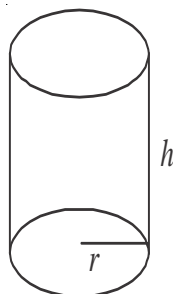

(a) For right circular cylinder solid, base radius =  $r$ , height =  $h$

$$\text{Volume} = \pi r^2 h$$

$$\text{Lateral surface area of solid cylinder} = 2\pi r h$$

$$\text{Total surface area of solid cylinder} = 2\pi r (r + h)$$

(b) For right circular cylinder (Hollow)

$$\text{external radius} = R$$

$$\text{internal radius} = r$$

$$\text{height} = h$$

$$\text{Volume} = \pi(R^2 - r^2)h$$

$$\text{Curved surface area} = 2\pi(R + r)h$$

$$\text{Total surface area} = 2\pi(R + r)h + 2\pi(R^2 - r^2)$$

4. **Cone:** 3-D shapes like conical tents, ice-cream cone are called Cone.

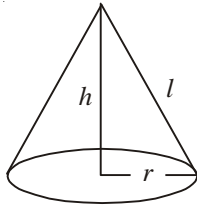

For right circular cone,

$$\text{base radius} = r$$

$$\text{height} = h$$

$$\text{slant height} = l$$

$$l = \sqrt{h^2 + r^2}$$

$$\text{Volume} = \frac{1}{3} \pi r^2 h$$

$$\text{Curved surface area of solid cone} = \pi r l$$

$$\text{Total surface area of solid cone} = \pi r (r + l)$$

It may be noted that if radius and height of a cone and cylinder are same then

$$3 \times \text{volume of a cone} = \text{volume of right circular cylinder}$$

5. **Sphere:** 3-D shapes like cricket balls, footballs etc. are called sphere.

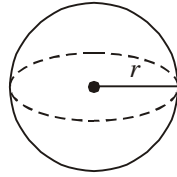

- (a) For sphere : Radius =  $r$

$$\text{Volume} = \frac{4}{3} \pi r^3$$

$$\text{surface area} = 4\pi r^2$$

- (b) For Hemisphere (solid): Radius =  $r$

$$\text{Volume} = \frac{2}{3} \pi r^3$$

$$\text{Curved surface area} = 2\pi r^2$$

$$\text{Total surface area} = 3\pi r^2$$

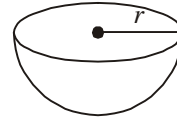

6. **Frustum:** When a cone is cut by a plane parallel to the base of the cone, then the portion between the plane and the base is called the frustum of the cone.

Example = Turkish Cap

For a frustum of cone:

Base radius =  $R$

Top radius =  $r$

Height =  $h$

slant height =  $l$

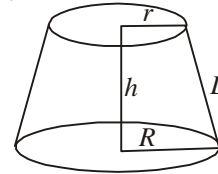

$$l = \sqrt{h^2 + (R - r)^2}$$

$$\text{volume} = \frac{1}{3} \pi h(r^2 + R^2 + Rr)$$

Curved surface area (solid frustum) =  $\pi l(R + r)$

Total surface area (solid frustum) =  $\pi l(R + r) + \pi(R^2 + r^2)$

### VERY SHORT ANSWER TYPE QUESTIONS

1. Match the following:

#### Column I

- (a) Surface area of a sphere
- (b) Total surface area of a cone
- (c) Volume of a cuboid
- (d) Volume of hemisphere
- (e) Curved surface area of a cone
- (f) Total surface area of hemisphere
- (g) Curved surface area of a cylinder
- (h) Volume of a cone
- (i) Total surface area of a cylinder
- (j) Volume of a frustum of a cone

#### Column II

- (i)  $2\pi rh$
- (ii)  $\frac{1}{2}\pi r^2 h$
- (iii)  $2\pi r\{r + h\}$
- (iv)  $\frac{1}{3}\pi h(r^2 + R^2 + rR)$
- (v)  $\pi r (r + 1)$
- (vi)  $l \times b \times h$
- (vii)  $\frac{2}{3}\pi r^3$
- (viii)  $\pi rl$
- (ix)  $3\pi r^2$
- (x)  $4\pi r^2$

2. Fill in the Wanks:

- (i) The total surface area of cuboid of dimension  $a \times a \times b$  is \_\_\_\_\_.
- (ii) The volume of right circular cylinder of base radius  $r$  and height  $2r$  is \_\_\_\_\_.
- (iii) The total surface area of a cylinder of base radius  $r$  and height  $h$  is \_\_\_\_\_.
- (iv) The curved surface area of a cone of base radius  $r$  and height  $h$  is \_\_\_\_\_.
- (v) If the height of a cone is equal to diameter of its base, the volume of cone is \_\_\_\_\_.
- (vi) The total surface area of a hemisphere of radius  $r$  is \_\_\_\_\_.
- (vii) The lateral surface area of a hollow cylinder of outer radius  $R$ , inner radius  $r$  and height  $h$  is \_\_\_\_\_.

- (viii) If the radius of a sphere is doubled, its volume becomes \_\_\_\_\_ times the volume of original sphere.
- (ix) If the radius of a sphere is halved, its volume becomes \_\_\_\_\_ times the volume of original sphere. (NCERT Exemplar)
3. Write 'True' or 'False' in the following:
- Two identical solid hemispheres of equal base radius  $r$  are stuck together along their bases. The total surface area of the combination is  $6\pi r^2$ .
  - A solid cylinder of radius  $r$  and height  $h$  is placed over other cylinder of same height and radius. The total surface area of the shape so formed is  $4\pi rh + 4\pi r^2$ .
  - A solid cone of radius  $r$  and height  $h$  is placed over a solid cylinder having same base radius and height as that of a cone. The total surface area of the combined.  $\pi r(\sqrt{r^2 + h^2} + 3r + 2h)$
  - A solid ball is exactly fitted inside the cubical box of side  $a$ . The volume of the ball is  $\frac{4}{3}\pi a^3$ .
  - The volume of the frustum of a cone is  $\frac{1}{3}\pi h(r_1^2 + r_2^2 + r_1 r_2)$ . where  $h$  is vertical height of the frustum and  $r_1, r_2$  are the radii of the ends.
4. The total surface area of a solid hemisphere of radius  $r$  is  
 (a)  $\pi r^2$       (b)  $2\pi r^2$       (c)  $3\pi r^2$       (d)  $4\pi r^2$
5. The volume and the surface area of a sphere are numerically equal, then the radius of sphere is  
 (a) 0 units      (b) 1 units      (c) 2 units      (d) 3 units
6. A cylinder, a cone and a hemisphere are of the same base and of the same height. The ratio of their volumes is  
 (a) 1:2:3      (b) 2:1:3      (c) 3:1:2      (d) 3:2:1
7. A solid sphere of radius ' $r$ ' is melted and recast into the shape of a solid cone of height ' $r$ '. Then the radius of the base of cone is  
 (a)  $2r$       (b)  $r$       (c)  $4r$       (d)  $3r$
8. Three solid spheres of diameters 6 cm, 8 cm and 10 cm are melted to form a single solid sphere. The diameter of the new sphere is  
 (a) 6 cm      (b) 4.5 cm      (c) 3 cm      (d) 12 cm

9. The radii of the ends of a frustum of a cone 40 cm high are 38 cm and 8 cm. The slant height of the frustum of cone is
- (a) 50 cm (b)  $10\sqrt{7}$  cm  
(c) 60.96 cm (d)  $4\sqrt{2}$  cm
10. A metallic spherical shell of internal and external diameters 4 cm and 8 cm, respectively is melted and recast into the form of a cone of base diameter 8 cm. The height of the cone is:
- (a) 12 cm (b) 14 cm  
(c) 15 cm (d) 18 cm
11. A solid piece of iron in the form of a cuboid of dimensions 49 cm  $\times$  33 cm  $\times$  24 cm, is moulded to form a solid sphere. The radius of the sphere is
- (a) 21 cm (b) 23 cm  
(c) 25 cm (d) 19 cm
12. A shuttle cock used for playing badminton has the shape of the combination of  
(NCERT Exemplar)
- (a) A cylinder and a sphere (b) a cylinder and a hemisphere  
(c) a sphere and a cone (d) frustum of a cone and hemisphere
13. The radii of the top and bottom of a bucket of slant height 45 cm are 28 cm and 7 cm, respectively. The curved surface area of the bucket is (NCERT Exemplar)
- (a)  $4950 \text{ cm}^2$  (b)  $4951 \text{ cm}^2$   
(c)  $4952 \text{ cm}^2$  (d)  $4953 \text{ cm}^2$
14. What geometrical shapes is a “FUNNEL” combination of?



15. What geometrical shapes is a cylindrical “PENCIL” sharpened at one edge combination of?



16. What geometrical 3-D shapes is a “GLASS (tumbler)”?



17. What geometrical shapes is a “GILLI” in gilli-danda game combination of?



18. A solid shape is converted from one form to another. What is the change in its volume?
19. What cross-section is made by a cone when it is cut parallel to its base?
20. Find total surface area of a solid hemi-sphere of radius 7cm.
21. Volume of two spheres is in the ratio 64 : 125. Find the ratio of their surface areas.
22. A cylinder and a cone are of same base radius and of same height. Find the ratio of the volumes of cylinder to that of the cone.
23. A solid sphere of radius  $r$  is melted and recast into the shape of a solid cone of height  $r$ . Find radius of the base of the cone.
24. If the volume of a cube is  $1331 \text{ cm}^3$ , then find the length of its edge.

### SHORT ANSWER TYPE QUESTION (TYPE-I)

25. How many cubes of side 2 cm can be cut from a cuboid measuring  $(16\text{cm} \times 12\text{cm} \times 10\text{cm})$ .
26. Find the height of largest right circular cone that can be cut out of a cube whose volume is  $729 \text{ cm}^3$ .
27. Two identical cubes each of volume  $64 \text{ cm}^3$  are joined together end to end. What is the surface area of the resulting cuboid?
28. Twelve solid spheres of the same sizes are made by melting a solid metallic cylinder of base diameter 2 cm and height 16cm. Find the radius of each sphere.
29. The diameters of the two circular ends of the bucket are 44 cm and 24 cm. The height of the bucket is 35cm. Find the volume of the bucket.

### SHORT ANSWER TYPE QUESTION (TYPE-II)

30. A bucket is in the form of a frustum of a cone and hold 28.490 litres of water. The radii of the top and bottom are 28 cm and 21 cm respectively. Find the height of the bucket.
31. Three cubes of a metal whose edge are in the ratio 3:4:5 are melted and converted into a single cube whose diagonal is  $12\sqrt{3}$  cm. Find the edge of three cubes.
32. Find the depth of a cylindrical tank of radius 10.5 cm, if its capacity is equal to that of a rectangular tank of size 15 cm  $\times$  11 cm  $\times$  10.5 cm.
33. A cone of radius 8cm and height 12cm is divided into two parts by a plane through the mid-point of its axis parallel to its base. Find the ratio of the volumes of the two parts.
34. A petrol tank is a cylinder of base diameter 28cm and length 24cm filled with conical ends each of axis length 9cm. Determine the capacity of the tank.
35. Water in a canal, 6 m wide and 1.5 m deep, is flowing with a speed of 10 km/hour. How much area will it irrigate in 30 minutes; if 8 cm standing water is needed? (NCERT CBSE 2019)
36. A solid is in the form of a cylinder with hemispherical ends. The total height of the solid is 20 cm and the diameter of the cylinder is 7 cm. Find the total volume of the solid. (Use  $V = \frac{22}{7}$ ) CBSE 2019
37. Two spheres of same metal weight 1 Kg and 7 Kg. The radius of the smaller sphere is 3 cm. The two spheres are melted to form a single big sphere. Find the diameter of the new sphere. CBSE 2019
38. A cone of height 24 cm and radius of base 6 cm is made up of modeling clay, A child reshapes it in the form of a sphere. Find the radius of the sphere and hence find the surface area of this sphere. (NCERT CBSE 2019)
39. A farmer connects a pipe of internal diameter 20 cm from a canal into a cylindrical tank in his field which is 10 m in diameter and 2 m deep. If water flows through pipe at the rate of 3 Km/hr, in How much time will the tank be filled? (NCERT CBSE 2019)

40. A juice seller was serving his customers using glasses as shown in figure. The inner diameter of the cylindrical glass was 5 cm but bottom of the glass had a hemispherical raised portion which reduced the capacity of the glass. If the height of a glass was 10 cm, find the apparent and actual capacity of the glass. { Use  $\pi$  } = 3.14 }

(NCERT CBSE 2019, 2009)

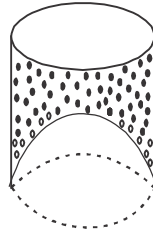

41. A girl empties a cylindrical bucket full of sand, of base radius 18 cm and height 32 cm on the floor to form a conical heap of sand. If the height of this conical heap is 24 cm, then find its slant height correct to one place of decimal.  
(CBSE 2019)
42. Water is flowing at the rate of 5 km/hour through a pipe of diameter 14 cm into a tank with rectangular base which is 50 m long and 44 m wide. Find the time in which the level of water tank rises by 7 cm. (Use  $\pi = \frac{22}{7}$  } (CBSE 2019)
43. A field is in the form of rectangle of length 20 m and width 14 m, A 10 m deep well of diameter 7 m is dug in one corner of the field and the earth taken out of the well is spread evenly over the remaining part of the field. Find the rise in the level of the field. ( Use  $\pi = \frac{22}{7}$  ) (CBSE 2019)

### LONG ANSWER TYPE QUESTIONS

44. A bucket open at the top is in the form of a frustum of a cone with a capacity of 12308.8 cm<sup>3</sup>. The radii of the top and bottom of the circular ends of the bucket are 20 cm and 12 cm respectively. Find the height of the bucket and also the area of the metal sheet used in making it. ( Use  $\pi = 3.14$  ) (CBSE 2019)
45. A solid iron pole consists of a cylinder of height 220 cm and base diameter 24 cm, which is surmounted by another cylinder of height 60 cm and radius 8 cm. Find the mass of the pole, given that 1 cm<sup>3</sup> of iron has approximately 8 gm mass. ( Use  $\pi = 3.14$  ) (NCERT CBSE 2019)

46. A right cylindrical container of radius 6 cm and height 15 cm is full of ice-cream, which has to be distributed to 10 children in equal cones having hemispherical shape on the top. If the height of the conical portion is four times its base radius, find the radius of the ice-cream cone. (CBSE 2019)
47. A container opened at the top and made up of a meta! sheet, is in the form of a frustum of a cone of height 16 cm with radii of its lower and upper ends as 8 cm and 20 cm respectively. Find the cost of milk which can completely fill the container, at the rate of ₹ 50 per litre. Also find the cost of meta! sheet used to make the container, if it costs ₹ 10 per 100 cm<sup>2</sup> ( Take  $\pi = 3.14$ ).  
(NCERT CBSE 2019)
48. An open metallic bucket is in the shape of a frustum of a cone, If the diameters of the two circular ends of the bucket are 45 cm and 25 cm and the vertical height of the bucket is 24 cm, find the area of the metallic sheet used to make the bucket. Also find the volume of the water it can hold. { Use  $\pi = \frac{22}{7}$  }.
49. In the given figure, from the top of a solid cone of height 12cm and base radius 6cm, a cone of height 4 cm is removed by a plane parallel to the base. Find the total surface area of the remaining solid. (Use  $\pi = \frac{22}{7}$  and  $\sqrt{5} = 2.236$ ) (CBSE – 2015)

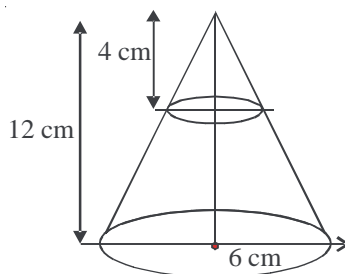

50. A solid wooden toy is in the form of a hemi-sphere surmounted by a cone of same radius. The radius of hemi-sphere is 3.5cm and the total wood used in the making of toy is  $166\frac{5}{6}$  cm<sup>3</sup>. Find the height of the toy. Also, find the cost of painting the hemi-spherical part of the toy at the rate of ₹ 10 per cm<sup>2</sup>.  
(use  $\pi = \frac{22}{7}$  ). (CBSE, 2015)

51. In the given figure, from a cuboidal solid metallic block of dimensions  $15\text{ cm} \times 10\text{ cm} \times 5\text{ cm}$  a cylindrical hole of diameter  $7\text{ cm}$  is drilled out. Find the surface area of the remaining block. (Use  $\pi = \frac{22}{7}$ ). (CBSE – 2015)

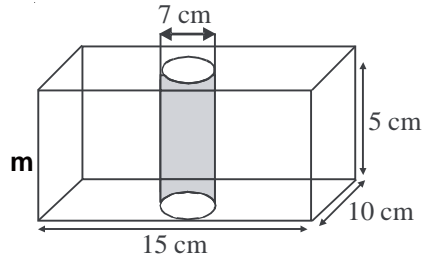

52. A solid toy is the form of a right circular cylinder with a hemispherical shape at one end and a cone at the other end. Their diameter is  $4.2\text{ cm}$  and the heights of the cylindrical and conical portions are  $12\text{ cm}$  and  $7\text{ cm}$  respectively. Find the volume of the toy.
53. A tent is in the shape of a right circular cylinder upto a height of  $3\text{ m}$  and conical above it. The total height of the tent is  $13.5\text{ m}$  and radius of base is  $14\text{ m}$ . Find the cost of cloth required to make the tent at the rate of ₹  $80$  per sq. m.
54. The rain water from a roof  $22\text{ m} \times 20\text{ m}$  drains into a cylindrical vessel having diameter of base  $2\text{ m}$  and height  $3.5\text{ m}$ . If the vessel is just full, find the rainfall in cm.
55. The difference between outer and inner curved surface areas of a hollow right circular cylinder,  $14\text{ cm}$  long is  $88\text{ cm}^2$ . If the volume of the metal used in making the cylinder is  $176\text{ cm}^3$ . Find the outer and inner diameters of the cylinder.

### ANSWERS AND HINTS

- |                                |  |
|--------------------------------|--|
| 1. (a) (x) $4\pi r^2$          | (b) (v) $\pi r (r + l)$                      |
| (c) (vi) $l \times b \times h$ | (d) (vii) $\frac{2}{3}\pi r^3$               |
| (e) (viii) $\pi r l$           | (f) (ix) $3\pi r^2$                          |
| (g) (i) $2\pi r h$             | (h) (ii) $\frac{1}{3}\pi r^2 h$              |
| (i) (iii) $2\pi r (r + h)$     | (j) (iv) $\frac{1}{3}\pi h (r^2 + R^2 + rR)$ |

2. (i)  $2a^2 + 4ab$  (ii)  $2\pi r^3$   
 (iii)  $2\pi r(r + h)$  (iv)  $\pi r\sqrt{r^2 + h^2}$   
 (v)  $\frac{2}{3}\pi r^3$  (vi)  $3\pi r^2$   
 (vii)  $2\pi h(R + r)$  (viii) 8  
 (ix)  $\frac{1}{8}$
3. (i) False (ii) False  
 (iii) False (iv) False  
 (v) True
4. (c)  $3\pi r^2$  5. (d) 3 units  
 6. (c) 3 : 1 : 2 7. (a) 2r  
 8. (d) 12 cm 9. (a) 50 cm  
 10. (b) 14 cm 11. (a) 21 cm  
 12. (d) Frustum of a cone and a hemisphere 13. (a)  $4950 \text{ cm}^2$   
 14. Cylinder and frustum of a cone 15. Cylinder and cone  
 16. Frustum of a cone 17. Cylinder with conical ends  
 18. Remains unchanged 19. Circle  
 20.  $462 \text{ cm}^2$  21. 16 : 25  
 22. 3 : 1 23. 2r  
 24. 11 cm
25. No. of cubes =  $\frac{16 \times 12 \times 10}{2 \times 2 \times 2} = 240$   
 26. Side of cube =  $\sqrt[3]{729} = 9 \text{ cm}$   
 Height of largest cone = Side of cube = 9 cm  
 27. Side of cube =  $\sqrt[3]{64} = 4 \text{ cm}$   
 Length, breadth and height of new cuboid is 8 cm, 4 cm and 4 cm respectively.  
 Surface area of cuboid =  $2[8 \times 4 + 4 \times 4 + 4 \times 8] = 160 \text{ cm}^2$

28. Volume of 12 solid sphere = Volume of solid cylinder

$$12 \times \frac{4}{3} \pi r^3 = \pi(1)^2 \times 16$$

$$r^3 = 1$$

$$r = 1 \text{ cm}$$

29. Volume of bucket =  $\frac{1}{3} \times \frac{22}{7} \times 35 [(22)^2 + (12)^2 + 22 \times 12]$

$$= 32706 \frac{2}{3} \text{ cm}^3$$

30. Volume of bucket = 28490 cm<sup>3</sup>

$$\frac{1}{3} \times \frac{22}{7} \times h [(28)^2 + (21)^2 + 28 \times 21] = 28490$$

$$h = 15 \text{ cm}$$

31. Let the edges of three cubes be 3x cm, 4x cm and 5x cm.

Volume of single cube = Sum of volume of three cubes

$$(\text{Side})^3 = (3x)^3 + (4x)^3 + (5x)^3$$

$$\text{Side} = 6x \text{ cm}$$

$$\text{Diagonal of single cube} = 12\sqrt{3}$$

$$\sqrt{3} (6x) = 12\sqrt{3}$$

$$x = 2$$

Hence edges of three cubes are 6 cm, 8 cm and 10 cm

32. Capacity of cylindrical tank = Capacity of rectangular tank

$$\frac{22}{7} \times (10.5)^2 \times h = 15 \times 11 \times 10.5$$

$$h = 5 \text{ cm}$$

33.  $\Delta OAB \sim \Delta OCD$

$$\frac{AB}{CD} = \frac{OA}{OC}$$

$$AB = 4 \text{ cm}$$

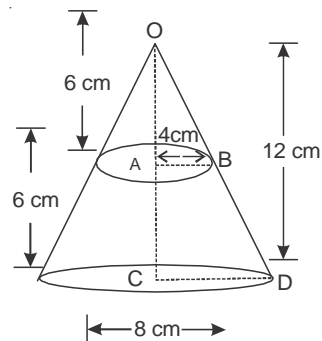

$$\frac{\text{Volume of conical part}}{\text{Volume of frustum part}} = \frac{\frac{1}{3} \pi (4)^2 \times 6}{\frac{1}{3} \pi \times 6 [(8)^2 + (4)^2 + 8 \times 4]} = \frac{1}{7}$$

∴ required ratio is 1 : 7 or 7 : 1

34. Capacity of tank = Volume of cylindrical part + 2 × Volume of conical part  
 = 18480 cm<sup>2</sup>

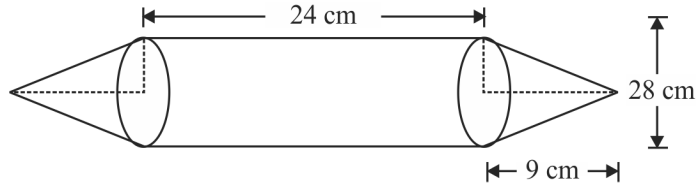

35. Length of canal covered in 30 mins = 5000 m

∴ Volume of water flown in 30 mins

$$= 6 \times 1.5 \times 5000 \text{ m}^3$$

$$\text{Area irrigated} = \frac{6 \times 1.5 \times 5000}{0.08} = 562500 \text{ m}^2$$

36. Height of cylinder = 20 – 3.5 – 3.5 = 13 cm

Volume of solid = Volume of cylindrical part + 2  
 × Volume of hemispherical part

$$= \frac{22}{7} \times (3.5)^2 \times 13 + 2 \times \frac{2}{3} \times \frac{22}{7} (3.5)^3$$

$$= 680 \frac{1}{6} \text{ cm}^3$$

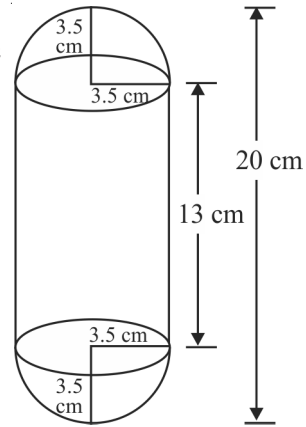

37. Radius of first sphere = 3 cm

Let density of metal be  $d \text{ kg/cm}^3$

$$\therefore \frac{4}{3} \pi (3)^3 \times d = 1 \quad \dots(1)$$

Let radius of second sphere be  $r \text{ cm}$ .

$$\therefore \frac{4}{3} \pi (r)^3 \times d = 7 \quad \dots(2)$$

From (1) and (2), we have

$$r^3 = 7(3)^3$$

Let the radius of new sphere be  $R \text{ cm}$ .

A.T.Q

$$\frac{4}{3} \pi R^3 = \frac{4}{3} \pi (3)^3 + \frac{4}{3} \pi r^3$$

$$R^3 = (3)^3 + 7(3)^3$$

$$R = 6 \text{ cm}$$

∴ Diameter of new sphere =  $2 \times 6 = 12 \text{ cm}$ .

38. Volume of sphere = Volume of cone

$$\frac{4}{3}\pi r^3 = \frac{1}{3}\pi(6)^2 \times 24$$

$$r = 6 \text{ cm}$$

$$\text{Surface area of sphere} = 4 \times \pi \times (6)^2 = 144 \pi \text{ cm}^2$$

39. Time to fill tank =  $\frac{\text{Volume of cylindrical tank}}{\text{Volume of water flown in 1 hour}}$

$$= \frac{\pi(50)^2 \times 2}{\pi\left(\frac{1}{10}\right)^2 \times 3000} = 100 \text{ minutes or 1 hour 40 minutes.}$$

40. Apparent capacity =  $3.14 \times \left(\frac{5}{2}\right)^2 \times 10 = 196.25 \text{ cm}^3$ .

Actual capacity = Volume of cylindrical part – Volume of hemispherical part

$$= 196.25 - \frac{2}{3} \times 3.14 \times \left(\frac{5}{2}\right)^3$$

$$= 163.54 \text{ cm}^3 \text{ approx}$$

41. Volume of conical heap = Volume of cylindrical bucket

$$\frac{1}{3}\pi r^2 \times 24 = \pi(18)^2 \times 32$$

$$r = 36 \text{ cm}$$

$$\text{Slant height, } l = \sqrt{(36)^2 + (24)^2} = 43.2 \text{ cm}$$

42. Volume of raised water in tank =  $50 \times 44 \times \frac{7}{100} = 154 \text{ m}^3$

$$\text{Volume of water flown in 1 hr} = \frac{22}{7} \times \left(\frac{7}{100}\right)^2 \times 5000 = 77 \text{ m}^3$$

$$\text{Time taken} = \frac{154}{77} = 2 \text{ hours}$$

43. Rise in level =  $\frac{\text{Earth taken out}}{\text{Area of the remaining part of field}}$

$$= \frac{\frac{22}{7} \times \left(\frac{7}{2}\right)^2 \times 10}{\left[20 \times 14 - \frac{22}{7} \times \frac{7}{2} \times \frac{7}{2}\right]} = 1.5 \text{ m approx.}$$

44. Volume of bucket = 12308.8 cm<sup>3</sup>

$$\frac{1}{3} \times 3.14 \times h [(20)^2 + (12)^2 + 20 \times 12] = 12308.8$$

$$h = 15 \text{ cm}$$

$$l = \sqrt{(15)^2 + (20 - 12)^2} = 17 \text{ cm}$$

Surface area of metal sheet used

$$= 3.14 \times 17 \times (20 + 12) + 3.14 \times (12)^2$$

$$= 2160.32 \text{ cm}^2$$

45.

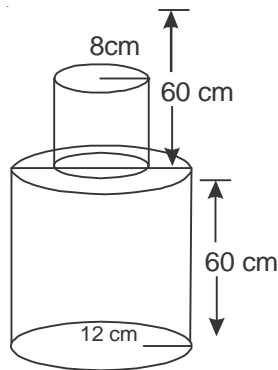

$$\text{Volume of solid} = 3.14 \times (12)^2 \times 60 + 3.14 \times (8)^2 \times 60$$

$$= 111532.8 \text{ cm}^3$$

$$\text{Mass of the pole} = 111532.8 \times \frac{8}{1000} \text{ kg}$$

$$= 892.2624 \text{ kg}$$

46. Let radius of conical section be  $r$  cm.

$\therefore$  Height of conical section be  $4r$  cm.

According to the question

$10 \times \text{Volume of ice-cream in 1 cone} = \text{Volume of cylindrical container}$

$$10 \times \left[ \frac{1}{3} \pi r^2 \times 4r + \frac{2}{3} \pi r^3 \right] = \pi(6)^2 \times 15$$

$$r = 3 \text{ cm}$$

$$47. \text{ Volume of the container} = \frac{3.14 \times 16}{3} [(20)^2 + (8)^2 + 20 \times 8]$$

$$= 10450 \text{ cm}^3 \text{ approx.}$$

$$= 10.45 \text{ litres}$$

$$\text{Cost of milk} = 10.45 \times 50 = ₹ 522.50$$

$$\text{Slant height} = \sqrt{(16)^2 + (20-8)^2} = 20 \text{ cm}$$

Surface area of container

$$= 3.14 \times 20 (20 + 8) + 3.14 \times (8)^2$$

$$= 1959.36 \text{ cm}^2$$

$$\text{Cost of metal sheet} = \frac{10}{100} \times 1959.36 = ₹ 195.94$$

$$48. \text{ Slant height} = \sqrt{(24)^2 + \left(\frac{45}{2} - \frac{25}{2}\right)^2} = 26 \text{ cm}$$

$$\text{Surface area of bucket} = \frac{22}{7} \times 26 \times \left(\frac{45}{2} + \frac{25}{2}\right) + \frac{22}{7} \times \frac{25}{2} \times \frac{25}{2}$$

$$= 3351.07 \text{ cm}^2 \text{ approx.}$$

$$\text{Volume} = \frac{1}{3} \times \frac{22}{7} \times 24 \times \left[ \left(\frac{45}{2}\right)^2 + \left(\frac{25}{2}\right)^2 + \frac{45}{2} \times \frac{25}{2} \right]$$

49. Radii of frustum are 6 cm and 2 cm.

$$\text{Height of frustum} = 12.4 = 8 \text{ cm}$$

$$\text{Slant height} = \sqrt{(8)^2 + (6.2)^2} = 4\sqrt{5} \text{ cm}$$

Total surface area of frustum

$$= \frac{22}{7} \times 4 \times 2.236 \times [6 + 2] + \frac{22}{7} \times (6)^2 + \frac{22}{7} \times (2)^2$$

$$= 350.592 \text{ cm}^2 \text{ approx.}$$

50. Volume of toy =  $\frac{1001}{6} \text{ cm}^3$

$$\frac{2}{3} \times \frac{22}{7} \times \left(\frac{7}{2}\right)^3 + \frac{1}{3} \times \frac{22}{7} \times \left(\frac{7}{2}\right)^2 \times h = \frac{1001}{6}$$

$$h = 6 \text{ cm}$$

Area of hemispherical part of toy

$$= 2 \times \frac{22}{7} \times \left(\frac{7}{2}\right)^2 = 77 \text{ cm}^2$$

Cost of painting =  $77 \times 10 = ₹ 770$

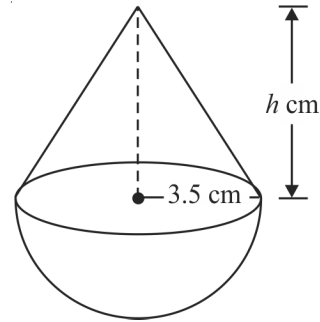

51. Surface of the remaining block = TSA of cuboidal block + CSA of cylinder

Area of two circular bases

$$= 2(15 \times 10 + 10 \times 5 + 15 \times 5) + 2 \times \frac{22}{7} \times \frac{7}{2} \times 5 - 2 \times \frac{22}{7} \times \left(\frac{7}{2}\right)^2$$

$$= 583 \text{ cm}^2$$

52. Volume of toy = Volume of cylindrical part + Volume of hemispherical part

+ Volume of conical part

$$= \frac{22}{7} \times (2.1)^2 \times 12 + \frac{1}{3} \times \frac{22}{7} \times (2.1)^2 \times 7 + \frac{2}{3} \times \frac{22}{7} \times (2.1)^3$$

$$= 218.064 \text{ cm}^3$$

53. Slant height =  $\sqrt{(14)^2 + (10.5)^2} = 17.5 \text{ m}$

$$\text{Surface area of tent} = 2 \times \frac{22}{7} \times 3 \times 14 + \frac{22}{7} \times 14 \times 17.5$$

$$= 1034 \text{ m}^2$$

Cost of cloth =  $1034 \times 80 = ₹ 82720$

54. Rainfall =  $\frac{\text{Volume of cylindrical vessel}}{\text{Area of roof}}$

$$= \frac{\frac{22}{7} \times (1)^2 \times 3.5}{22 \times 20} = \frac{1}{40} \text{ m}$$

$$= \frac{1}{40} \times 100 \text{ cm} = 2.5 \text{ cm}$$

55. Let inner and outer radius of hollow cylinder be  $r$  cm and  $R$  cm respectively.

Difference between Outer and Inner CSA =  $88 \text{ cm}^2$

$$2 \times \frac{22}{7} \times 14 \times [R - r] = 88$$

$$R - r = 1 \quad \dots(1)$$

Volume of hollow cylinder =  $176 \text{ cm}^3$

$$\frac{22}{7} \times 14 \times [R^2 - r^2] = 176$$

$$R^2 - r^2 = 4$$

$$(R - r)(R + r) = 4$$

$$R + r = 4$$

$$\dots(2) \quad [\because \text{ from (1)}]$$

From (1) and (2), we get

$$R = 2.5 \text{ cm and } r = 1.5 \text{ cm}$$

$\therefore$  Outer and inner diameter are 5 cm and 3 cm respectively.

# PRACTICE-TEST

## SURFACE AREAS AND VOLUMES

Time : 1 Hr.

M.M.: 20

### SECTION-A

1. The total surface area of a hemisphere of radius  $r$  is ..... 1
2. Which two geometrical shapes are obtained by cutting a cone parallel to its base? 1
  - (a) a cylinder and a cone
  - (b) a cone and a hemisphere
  - (c) a sphere and a cone
  - (d) frustum of a cone and a cone
3. The radius (in cm) of the largest right circular cone that can be cut out from a cube of edge 4.2 cm is 1
  - (a) 4.2
  - (b) 2.1
  - (c) 8.4
  - (d) 1.05
4. The volume of a cube is  $1000 \text{ cm}^3$ . Find the length of the side of the cube. 1

### SECTION-B

5. The radii of the ends of a frustum of a cone 45 cm high are 28 cm and 7 cm. Find its volume. 2
6. A solid sphere of radius 10.5 cm is melted and recast into smaller solid cones, each of radius 3.5 cm and height 3 cm. Find the number of cones so formed. 2
7. A cube and a sphere have equal total surface area. Find the ratio of the volume of sphere and cube. 2

### SECTION-C

8. A vessel is in the form of an inverted cone. Its height is 8 cm and the radius of its top, which is open, is 5 cm. It is filled with water up to brim. When lead shots, each of which is a sphere of radius 0.5 cm are dropped in to the vessel, one-fourth of the water flows out. Find the number of lead shots dropped in the vessel. 3
9. A large right circular cone is made out of a solid cube edge 9 cm. Find the volume of the remaining solid. 3

### SECTION-D

10. In a hospital, used water is collected in a cylindrical tank of diameter 2 m and height 5 m. After recycling, this water is used to irrigate a park of hospital whose length is 25 m and breadth is 20 m. If tank is filled completely then what will be the height of standing water used for irrigating the park? 4

Mathematics-X